

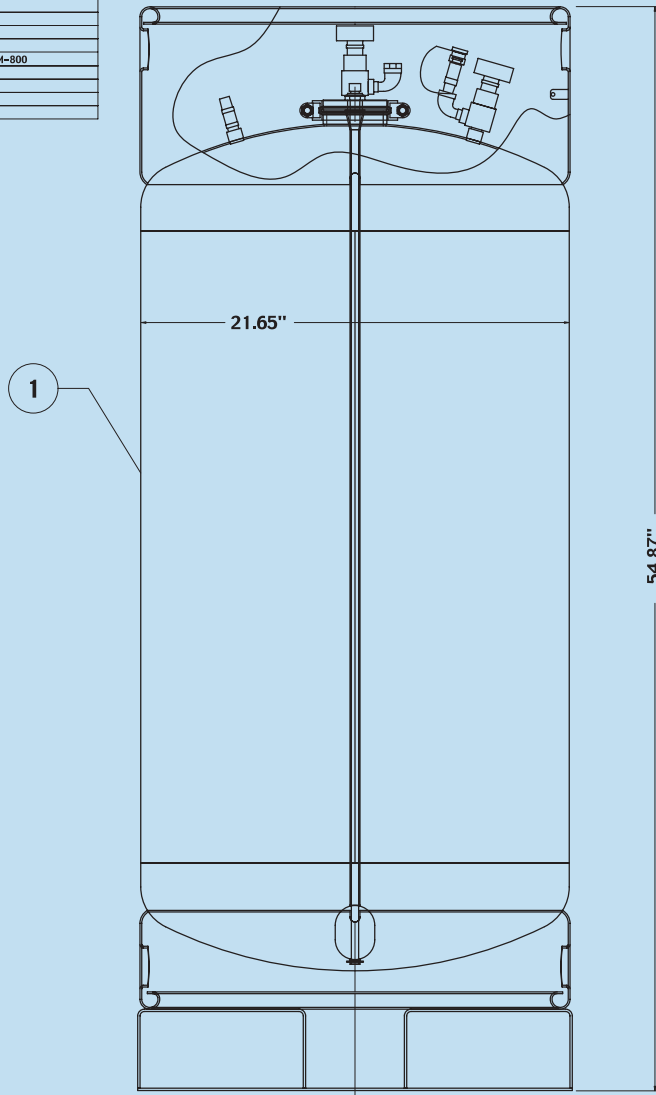

BILL OF MATERIALS			
ITEM	DESCRIPTION	QTY	MATERIAL DESCRIPTION
1	550mm ASME VESSEL	1	AS PER DWG. A0070131
2	ASME BURST DISC	1	56 FSI
3	PLASTIC PLUG	1	PLASTIC
4	PRESSURE RELIEF VALVE - 50PSI	1	SWAGELOCK
5	PRESSURE GAUGE - GLYCERIN FILLED	1	
6	1/4" PLUG	1	SS
7	1/4" 90° STREET ELBOW	2	SS
8	QUICK CONNECT, 1/4"	1	SWAGELOCK
9	DOWNTUBE ASSEMBLY W/ 3" T.C.	1	SS
10	LEVEL SENSOR - SPIN W/CAP	1	GEMS - MINI XM-800
11	1/2" X 1/4" NPT, RED, BUSHING	1	SS
12	DIAPHRAGM VALVE	2	SWAGELOCK
13	PLASTIC CAP	1	SWAGELOCK
14	GREEN CAP W/LANYARD	1	PLASTIC

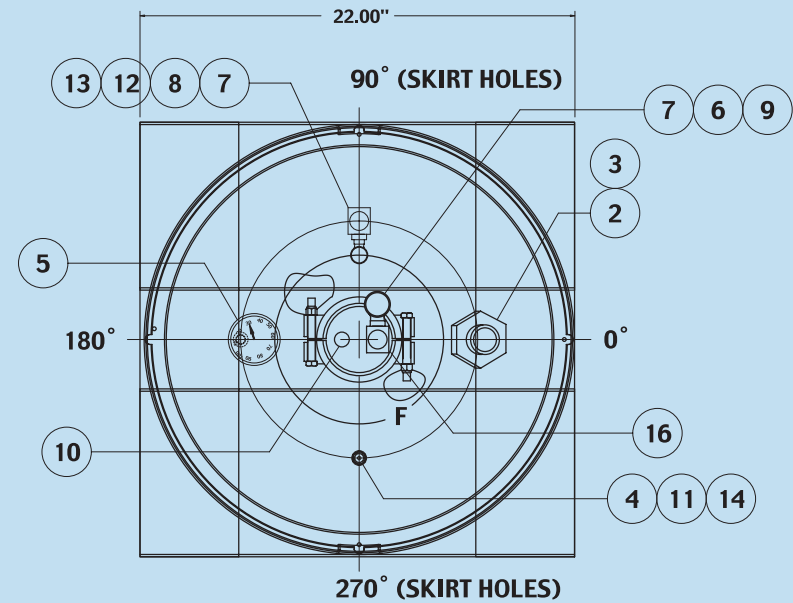

Chemical	Weight (lbs)	Grade	Part Number
1-Propanol	370	CMOS™	9061
2-Propanol	370	Finyte™-1	5986
Acetone	370	CMOS	9015
BTS-220 (PGMEA)	458	BAKER ALEG™	6333
BTS-280 (Ethyl Lactate)	495	BAKER ALEG	6312
n-Butyl Acetate	413	CMOS	9171
Chlorobenzene	522	CMOS	9179
Hexamethyldisilazane	362	CMOS	9362
Hexamethyldisilazane	362	Finyte	5798
Methanol	370	CMOS	9063
Xylenes	405	CMOS	9483



Material of
Stainless Steel
 Construction

Mallinckrodt Baker