

Chemical	Weight (lbs)	Grade	Part Number
Ammonium Hydroxide	290	CMOS™	9741
Ammonium Hydroxide	290	Finyte™	5817
Hydrochloric Acid	380	CMOS	9529
Hydrochloric Acid	380	Finyte	5814

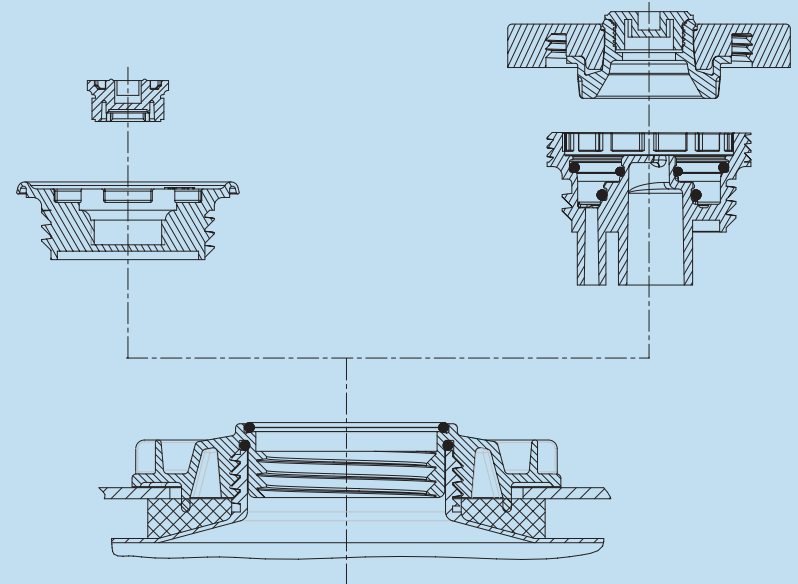

Mallinckrodt Baker