

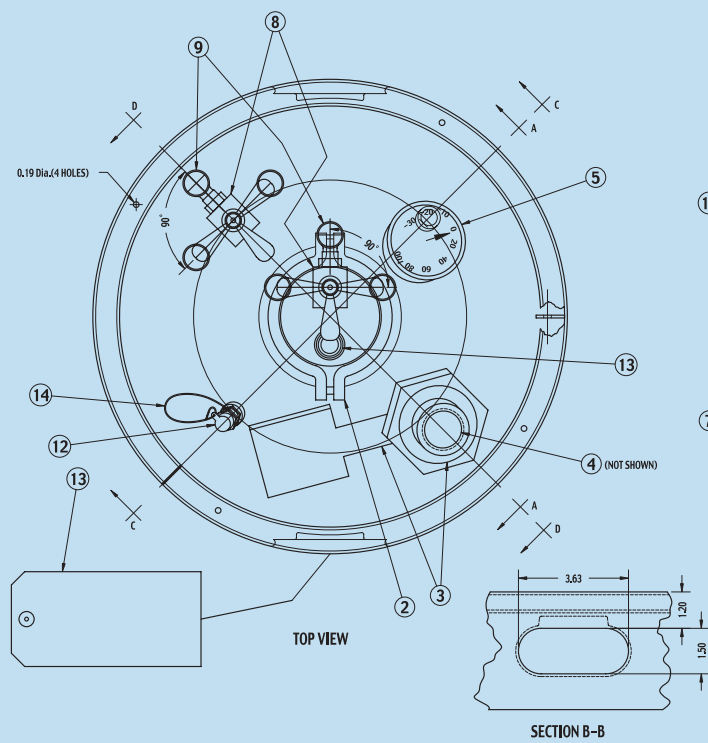

BILL OF MATERIALS		
ITEM	DESCRIPTION	MATERIAL
1	VESSEL ASSEMBLY	SA240, T304/L
2	CLAMP, 3" HIGH PRESSURE	
3	BURST DISK, 56 PSI	316 SS
4	PLUG, PLASTIC	
5	PRESSURE GAUGE	
6	DOWN TUBE, 0.5" DIA. X 21.8" LONG	304 SS
7	GASKET, 3"	TEFLON
8	VALVE, DIAPHRAGM	316 SS/TFE
9	STREET ELBOW, 1/4" 90°, 150	304 SS
10	PLUG, 1/4" NPT, 150	304 SS
11	LEVEL SENSOR/CAP	
12	PRESSURE RELIEF W/CAP, 50 PSI	316 SS
13	LABEL, PRESSURE WARNING	
14	WIRE ROPE, 5/64" DIA, NYLON COATED	304 SS

Chemical	Weight (lbs)	Grade	Part Number
1-Propanol	90	CMOS™	9061
2-Propanol	90	CMOS	9059
2-Propanol	90	Finyte™	5863
2-Propanol	90	Finyte-1	5986
Acetone	90	CMOS	9015
BTS-220 (PGMEA)	111	BAKER ALEG™	6333
BTS-280 (Ethyl Lactate)	120	BAKER ALEG	6312
n-Butyl Acetate	101	CMOS	9171
Chlorobenzene	127	CMOS	9179
Hexamethyldisilazane	88	CMOS	9362
Hexamethyldisilazane	88	Finyte	5798
Methanol	90	CMOS	9063
Xylenes	99	CMOS	9483



Material of
Stainless Steel
 Construction

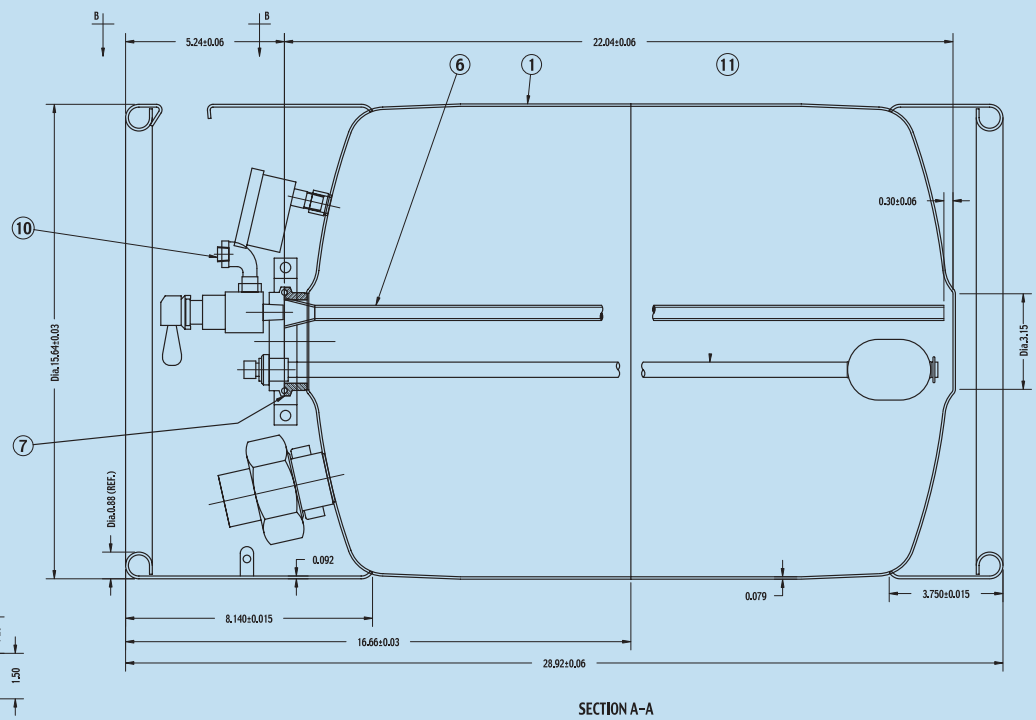

Mallinckrodt Baker