

Chemical	Weight (lbs)	Grade	Part Number
2-Propanol	330	CMOS™	9059
Aluminum Etchant	700	CMOS	5457
Ammonium Fluoride	500	CMOS	0712
Buffered Oxide Etch	500	CMOS	9289
Ethylene Glycol	500	CMOS	9356
HF DIP	450	CMOS	9288
Hydrogen Peroxide	500	CMOS	2200
Hydrogen Peroxide	500	Finyte™	5816
Hydrogen Peroxide	500	Finyte-1	5803
Hydrofluoric Acid	500	CMOS	9574
Hydrofluoric Acid	500	Finyte	5818
1-Methyl-2-Pyrrolidinone	460	Finyte	6347

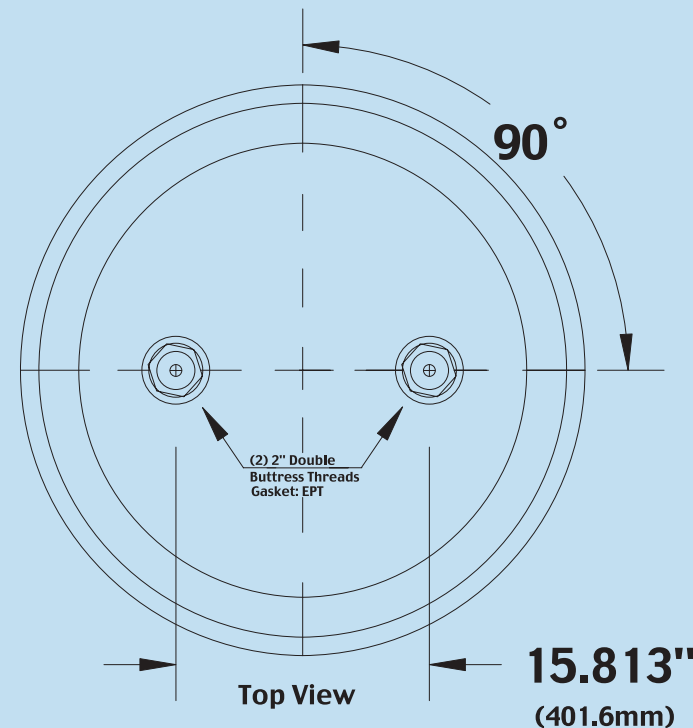

Material of
HDPE
 Construction

Mallinckrodt Baker