

Chemical	Weight (lbs)	Grade	Part Number
1-Propanol	330	CMOS™	9061
2-Propanol	330	CMOS	9059
Acetic Acid	450	CMOS	9513
Acetone	330	CMOS	9015
Ethylene Glycol	500	CMOS	9356
Hydrogen Peroxide	500	CMOS	2200
Hydrogen Peroxide	500	Finyte™	5816
Hydrogen Peroxide	500	Finyte-1	5803
Hydrofluoric Acid	500	CMOS	9574
Hydrofluoric Acid	500	Finyte	5818
Methanol	330	CMOS	9063
1-Methyl-2-Pyrrolidinone	460	BAKER ALEG™	6407
1-Methyl-2-Pyrrolidinone	460	Finyte	6437
Phosphoric Acid	700	CMOS	274
Potassium Hydroxide, 45%	600	Elec	3149
Sodium Hydroxide, 50%	600	Elec	3725
Sulfuric Acid	750	CMOS	9674
Sulfuric Acid	750	Finyte	5815

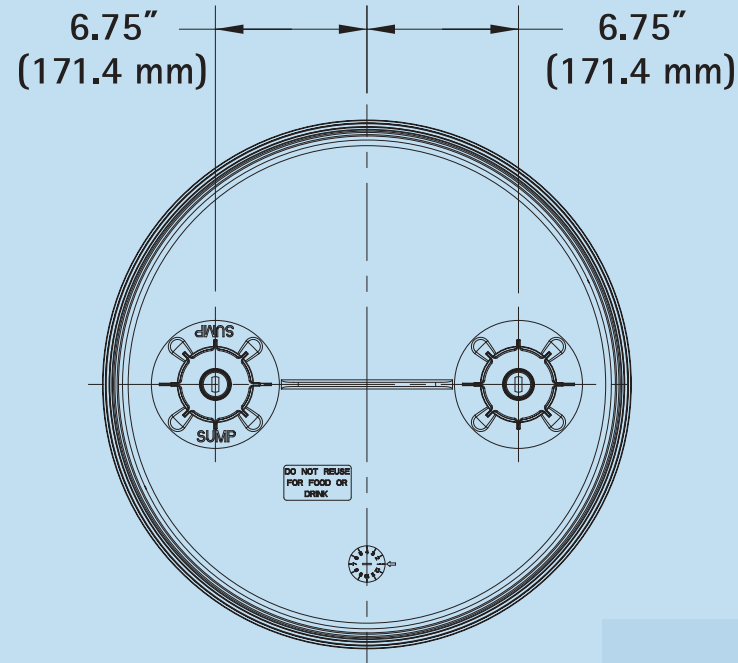

Material of  
**HDPE**  
 Construction

Tri-layer: Three layers of polyethylene; inner virgin layer.

Mallinckrodt Baker